

A/D CONVERTER SOLUTIONS

Analog, Digital & Mixed-Signal ICs, Modules, Subsystems & Instrumentation

High Speed Analog-to-Digital Converter Product Selection Guide!

Communications Infrastructure

- Digital Pre-Distortion (DPD) Loops** ◆
- Direct Conversion Receivers** ◆
- Diversity (MIMO) Receivers** ◆

Instrumentation

- Digital Oscilloscopes** ◆
- Spectrum Analyzers** ◆
- Hi-Definition Video Digitizing** ◆

Sensing & Control

- Ultrasound** ◆
- Magnetic Resonance Imaging (MRI)** ◆
- Radar & Security Sensors** ◆
- Radio Astronomy & Atmospheric LIDAR** ◆

Analog-to-Digital Converter Solutions

We offer Analog-to-Digital Converters (ADCs) that combine high speed and high SNR performance with lowest power dissipation. These ADCs provide uniquely configurable functionality including: crosspoint switches, clock dividers and programmable sampling rates / resolution / number of channels.

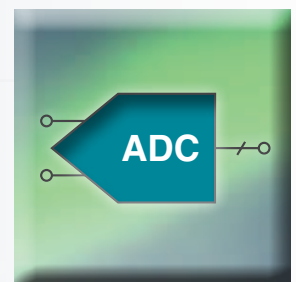

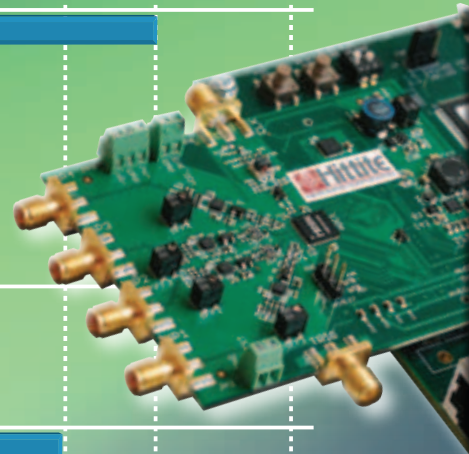
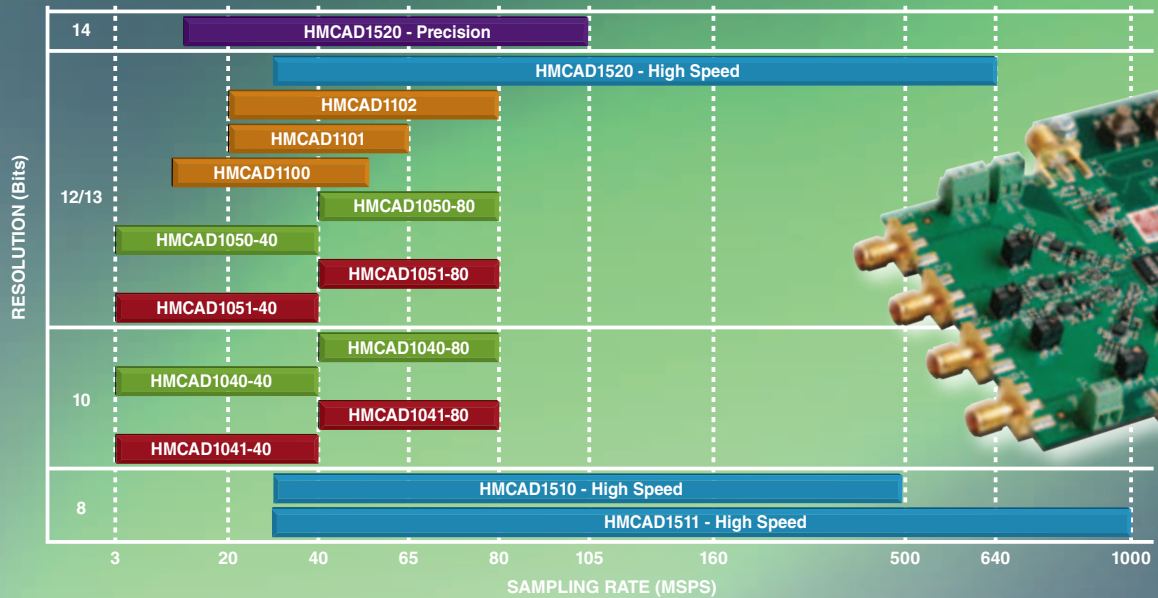

Standard Analog-to-Digital Converter Products

Page 3

Hittite offers a wide range of High Speed ADCs for Communication, Instrumentation, Industrial, Medical & Military applications. Low power consumption & high performance is combined with a high degree of flexibility.

- Sampling Rates: 3 to 1000 MSPS
- Resolution: 8 to 14 bits
- CMOS & LVDS Outputs
- Configurable Power Consumption & Functionality with SPI Settings
- Integrated Instrumentation Functionality



EasySuite™ Eval Kits

Analog Made Easy™

With our **Analog Made Easy™** philosophy, we are committed to user friendly products. We have built multiple features & functionality into our ADCs that make our products easy to use, thus reducing overall cost for the system designer.

- EasySuite™: Evaluation and Prototyping Platform Environment
- EasyBoard™: Supplied Evaluation Board Connected to Xilinx® Standard FMC Board
- EasyStack™: Firmware Code Stack, Currently Available for Xilinx®

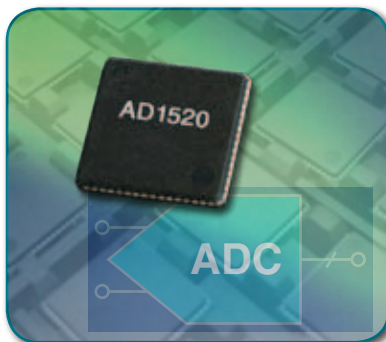

Custom Analog-to-Digital Converter Solutions

Hittite offers ADCs with customer specified integrated functions.

- Integrated LNA, VGAs and Analog Multiplexers (Analog Front End)
- Digital DownConverters (DDC)
- LVDS and JESD204 Outputs
- MCMs integrating RF and Microwave Functions with ADCs
- Ultra High Speed GSPS ADCs, page 10

High Speed, Low Power Analog-to-Digital Converters

Part Number	Function / Mode	Resolution (bits)	Sample Rate	# of Channels	Power Dissipation [2][3]	SNR (dBFS)	SFDR (dBc)	Package	ECCN Code	EasySuite™ Evaluation Kit P/N
HMCAD1520	High Speed, Single Channel	12	640 MSPS	1	490 mW	70	60 / 75 [1]	LP7DE	3A001.a.5.a.4	EKIT01-HMCAD1520
	High Speed, Dual Channel	12	320 MSPS	2	490 mW	70	60 / 78 [1]		3A001.a.5.a.4	EKIT01-HMCAD1520
	High Speed, Quad Channel	12	160 MSPS	4	490 mW	70	60 / 78 [1]		3A001.a.5.a.4	EKIT01-HMCAD1520
	Precision, Quad Channel	14	105 MSPS 80 MSPS	4 4	603 mW 530 mW	74 75	83 85		3A001.a.5.a.4	EKIT01-HMCAD1520
HMCAD1511	High Speed, Single Channel	8	1 GSPS	1	710 mW	49.8	49 / 64 [1]	LP7DE	3A001.a.5.a.1	EKIT01-HMCAD1511
	High Speed, Dual Channel	8	500 MSPS	2	710 mW	49.8	44 / 63 [1]		3A001.a.5.a.1	EKIT01-HMCAD1511
	High Speed, Quad Channel	8	250 MSPS	4	710 mW	49.8	57 / 70 [1]		3A001.a.5.a.1	EKIT01-HMCAD1511
HMCAD1510	High Speed, Single Channel	8	500 MSPS	1	295 mW	49.8	49 / 65 [1]	LP7DE	3A991.c.1	EKIT01-HMCAD1510
	High Speed, Dual Channel	8	250 MSPS	2	295 mW	49.8	59 / 69 [1]		3A991.c.1	EKIT01-HMCAD1510
	High Speed, Quad Channel	8	125 MSPS	4	295 mW	49.7	60 / 69 [1]		3A991.c.1	EKIT01-HMCAD1510
HMCAD1102	Octal Channel	13 / 12	80 MSPS	8	59 mW / Channel	70.1	77	LP9E	3A001.a.5.a.4	EKIT01-HMCAD1102
HMCAD1101	Octal Channel	13 / 12	65 MSPS	8	51 mW / Channel	72.2	82	LP9E	3A001.a.5.a.4	EKIT01-HMCAD1101
HMCAD1100	Octal Channel	13 / 12	50 MSPS	8	41 mW / Channel	72.2	82	LP9E	3A001.a.5.a.4	EKIT01-HMCAD1100
	Octal Channel	13 / 12	40 MSPS	8	35 mW / Channel	72.2	82		3A001.a.5.a.4	EKIT01-HMCAD1100
	Octal Channel	13 / 12	20 MSPS	8	23 mW / Channel	72.2	82		3A001.a.5.a.4	EKIT01-HMCAD1100
HMCAD1050-80	Dual Channel	13 / 12	80 MSPS	2	102 mW	72	77	LP9AE	3A001.a.5.a.4	EKIT01-HMCAD1050-80
	Dual Channel	13 / 12	65 MSPS	2	85 mW	72.6	81		3A001.a.5.a.4	EKIT01-HMCAD1050-80
HMCAD1050-40	Dual Channel	13 / 12	40 MSPS	2	55 mW	72.7	81	LP9AE	3A001.a.5.a.4	EKIT01-HMCAD1050-40
	Dual Channel	13 / 12	20 MSPS	2	30 mW	72.2	85		3A001.a.5.a.4	EKIT01-HMCAD1050-40
HMCAD1051-80	Single Channel	13 / 12	80 MSPS	1	60 mW	72	77	LP6HE	3A001.a.5.a.4	EKIT01-HMCAD1051-80
	Single Channel	13 / 12	65 MSPS	1	50 mW	72.6	81		3A001.a.5.a.4	EKIT01-HMCAD1051-80
HMCAD1051-40	Single Channel	13 / 12	40 MSPS	1	33 mW	72.7	81	LP6HE	3A001.a.5.a.4	EKIT01-HMCAD1051-40
	Single Channel	13 / 12	20 MSPS	1	19 mW	72.2	85		3A001.a.5.a.4	EKIT01-HMCAD1051-40
HMCAD1040-80	Dual Channel	10	80 MSPS	2	78 mW	61.6	75	LP9AE	EAR99	EKIT01-HMCAD1040-80
	Dual Channel	10	65 MSPS	2	65 mW	61.6	77		EAR99	EKIT01-HMCAD1040-80
HMCAD1040-40	Dual Channel	10	40 MSPS	2	43 mW	61.6	81	LP9AE	EAR99	EKIT01-HMCAD1040-40
	Dual Channel	10	20 MSPS	2	24 mW	61.6	81		EAR99	EKIT01-HMCAD1040-40
HMCAD1041-80	Single Channel	10	80 MSPS	1	46 mW	61.6	75	LP6HE	EAR99	EKIT01-HMCAD1041-80
	Single Channel	10	65 MSPS	1	38 mW	61.6	77		EAR99	EKIT01-HMCAD1041-80
HMCAD1041-40	Single Channel	10	40 MSPS	1	25 mW	61.6	81	LP6HE	EAR99	EKIT01-HMCAD1041-40
	Single Channel	10	20 MSPS	1	15 mW	61.6	81		EAR99	EKIT01-HMCAD1041-40

[1] Excluding Interleaving Spurs. [2] Supply Voltage (Vdd): +1.8 Vdc Analog Supply (AVdd) and +1.8 Vdc Digital Supply (DVdd) [3] Output Supply Voltage (OVdd): +1.7 to +3.6 Vdc

Hittite has consolidated the original Arctic Silicon Devices (ASD) part number options by their sampling rates into 14 Hittite part numbers. No ASD parts were discontinued. Contact: adc@hittite.com

HIGH SPEED / LOW POWER A/D CONVERTERS

Digital Pre-Distortion (DPD) Receiver Subsystem Featuring the HMCAD1520

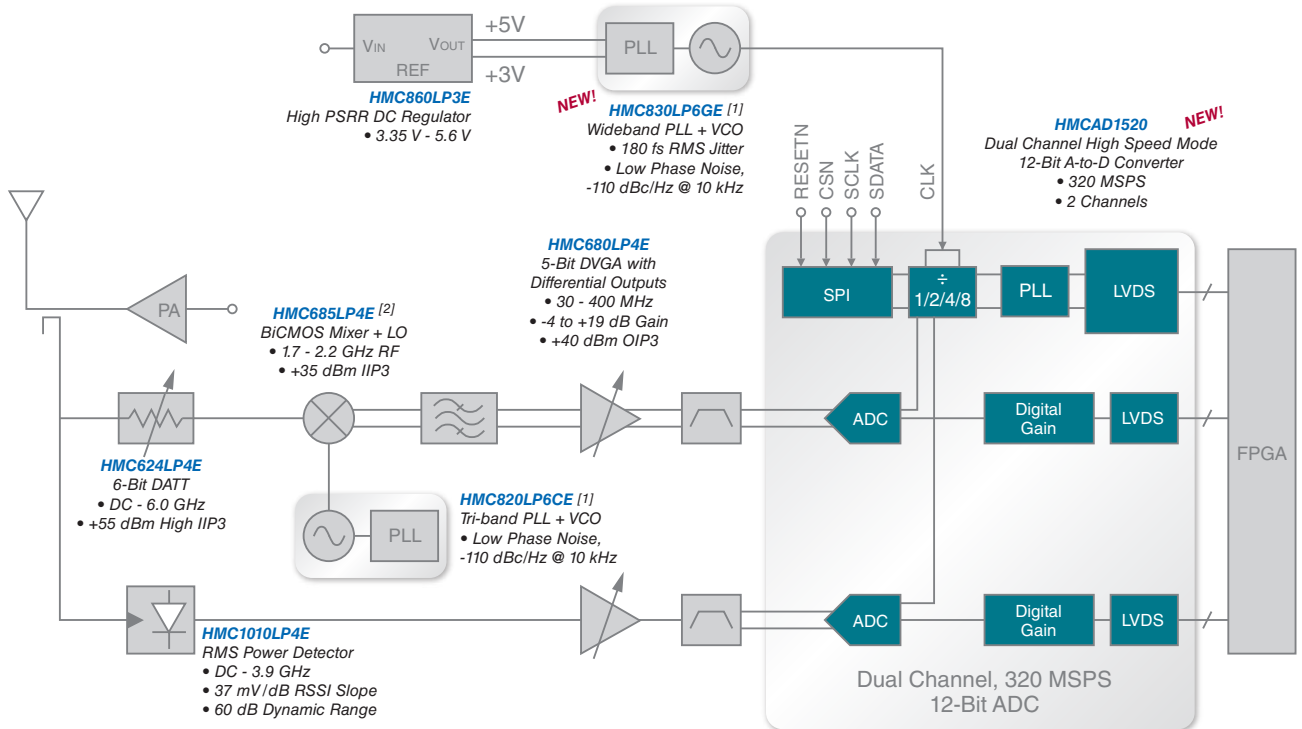

[1] You may choose from a variety of HMC PLL+VCO combinations specific to your application

[2] You may choose from a variety of MMIC Mixers specific to your application

A/D Converter Applications

Communications Infrastructure

Direct Conversion Receiver with Diversity Featuring the HMCAD1520

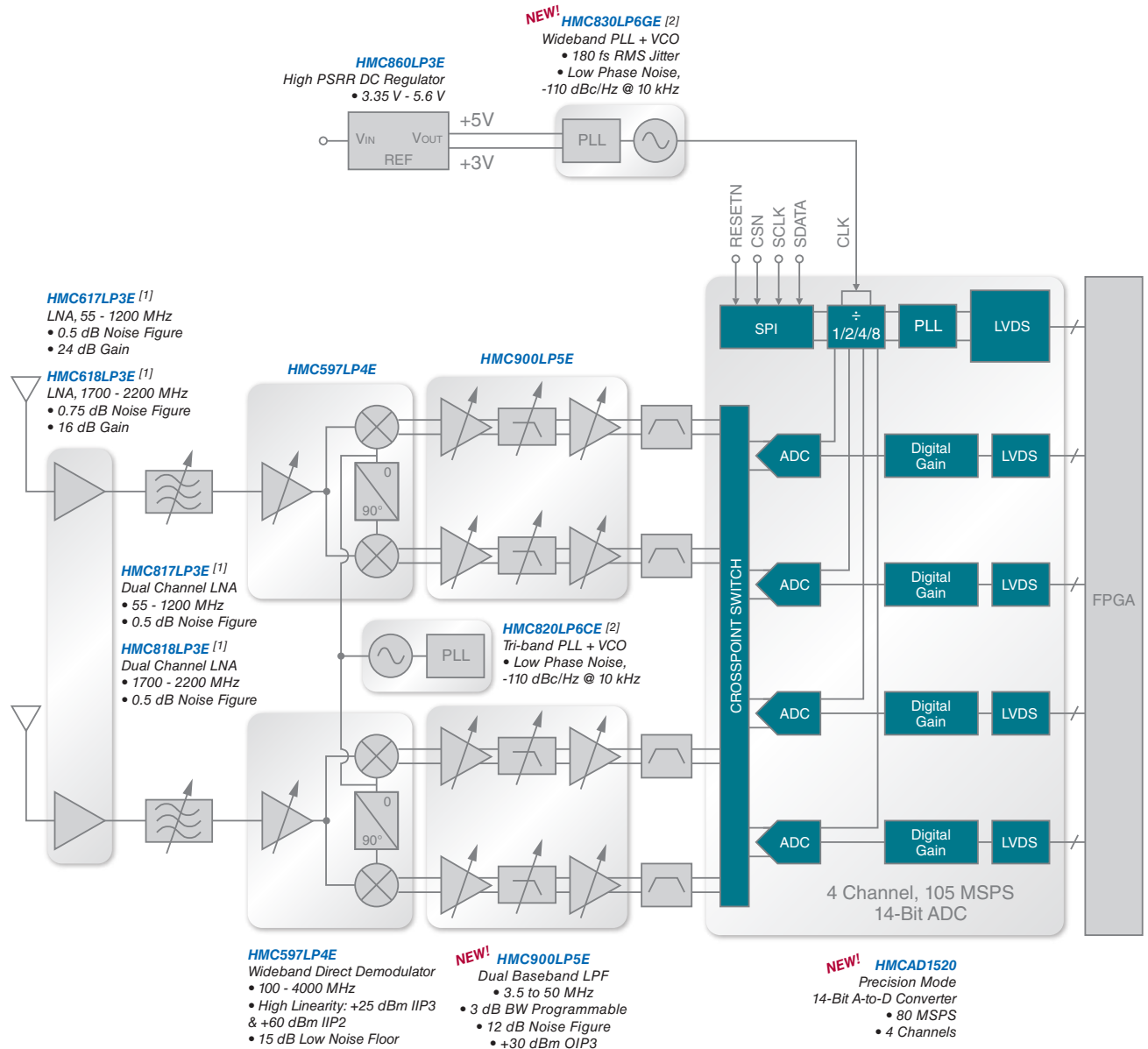

[1] You may choose from a variety of HMC LNAs specific to your application
 [2] You may choose from a variety of HMC PLL+VCO combinations specific to your application

Heterodyne Receiver with MIMO Featuring the HMCAD1520

A/D CONVERTER APPLICATIONS

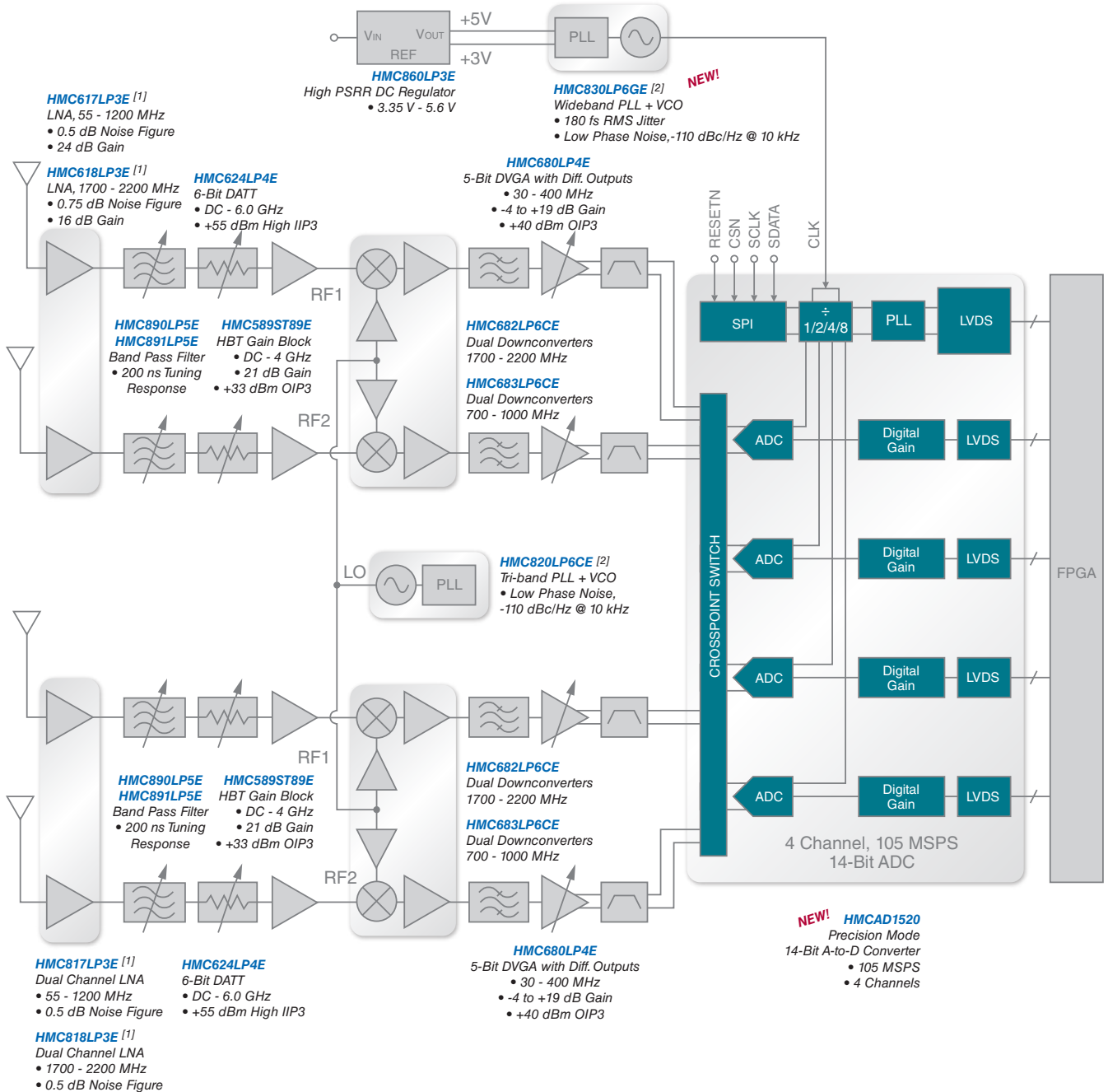

[1] You may choose from a variety of HMC LNAs specific to your application
 [2] You may choose from a variety of HMC PLL+VCO combinations specific to your application

A/D Converter Applications

Instrumentation

Digital Oscilloscopes Featuring the HMCAD1510 & HMCAD1511

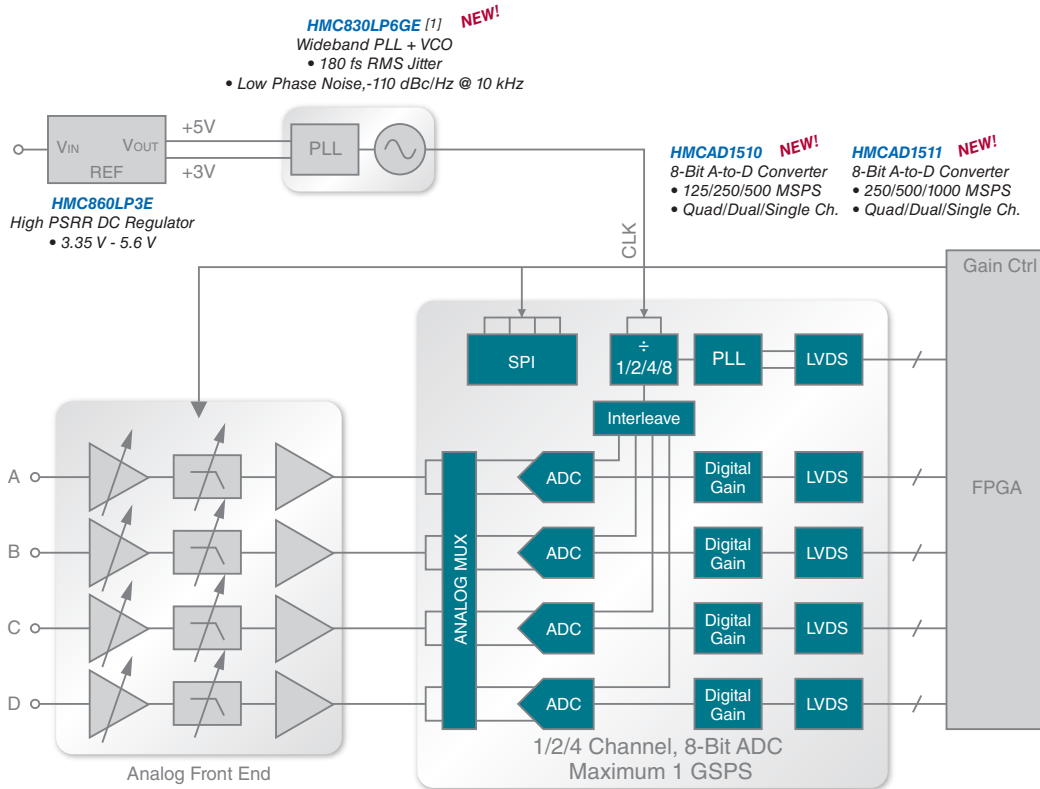

SNR with Digital Gain Compared with Traditional Ideal 8-Bit Converter

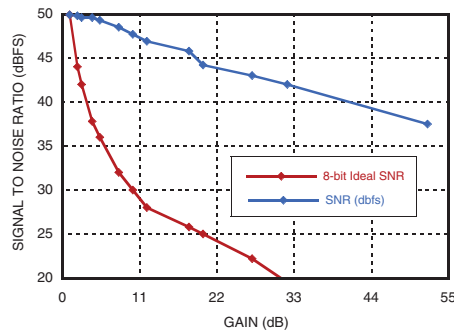

Part Number	Function / Mode	Resolution (bits)	Sample Rate	# of Channels	Power Dissipation [3][4]	SNR (dBFS)	SFDR (dBc)
HMCAD1511	Single Channel	8	1 GSPS	1	710 mW	49.8	49 / 64 [2]
	Dual Channel	8	500 MSPS	2	710 mW	49.8	44 / 63 [2]
	Quad Channel	8	250 MSPS	4	710 mW	49.8	57 / 70 [2]
HMCAD1510	Single Channel	8	500 MSPS	1	295 mW	49.8	49 / 65 [2]
	Dual Channel	8	250 MSPS	2	295 mW	49.8	59 / 69 [2]
	Quad Channel	8	125 MSPS	4	295 mW	49.7	60 / 69 [2]

[2] Excluding Interleaving Spurs.

[3] Supply Voltage (Vdd): +1.8 Vdc Analog Supply (AVdd) and +1.8 Vdc Digital Supply (DVdd)

[4] Output Supply Voltage (OVdd): +1.7 to +3.6 Vdc

[1] You may choose from a variety of HMC PLL+VCO combinations specific to your application

Spectrum Analyzers Featuring the HMCAD1520 In Precision Mode

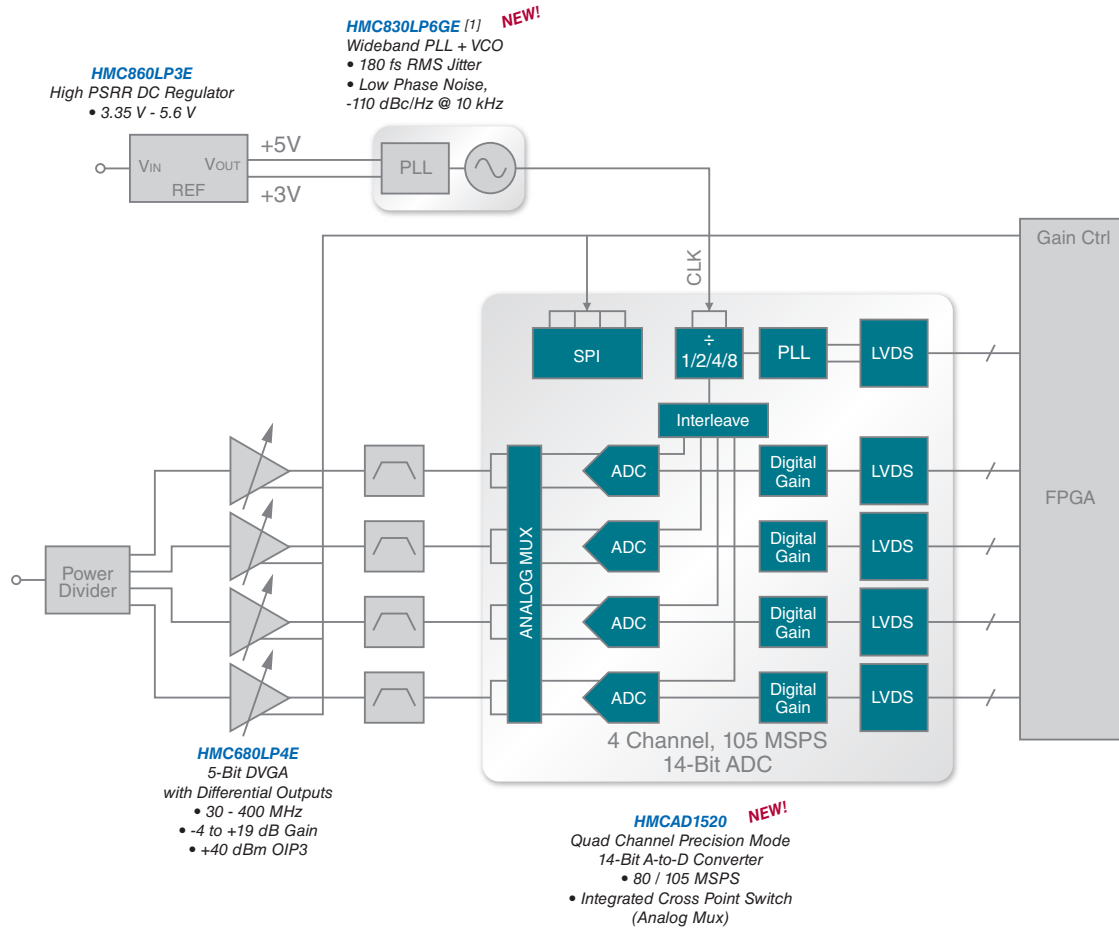

[1] You may choose from a variety of HMC PLL+VCO combinations specific to your application

A/D Converter Applications

Sensing & Control

Medical & Industrial Imaging (Ultrasound) Featuring the HMCAD1100/1101/1102

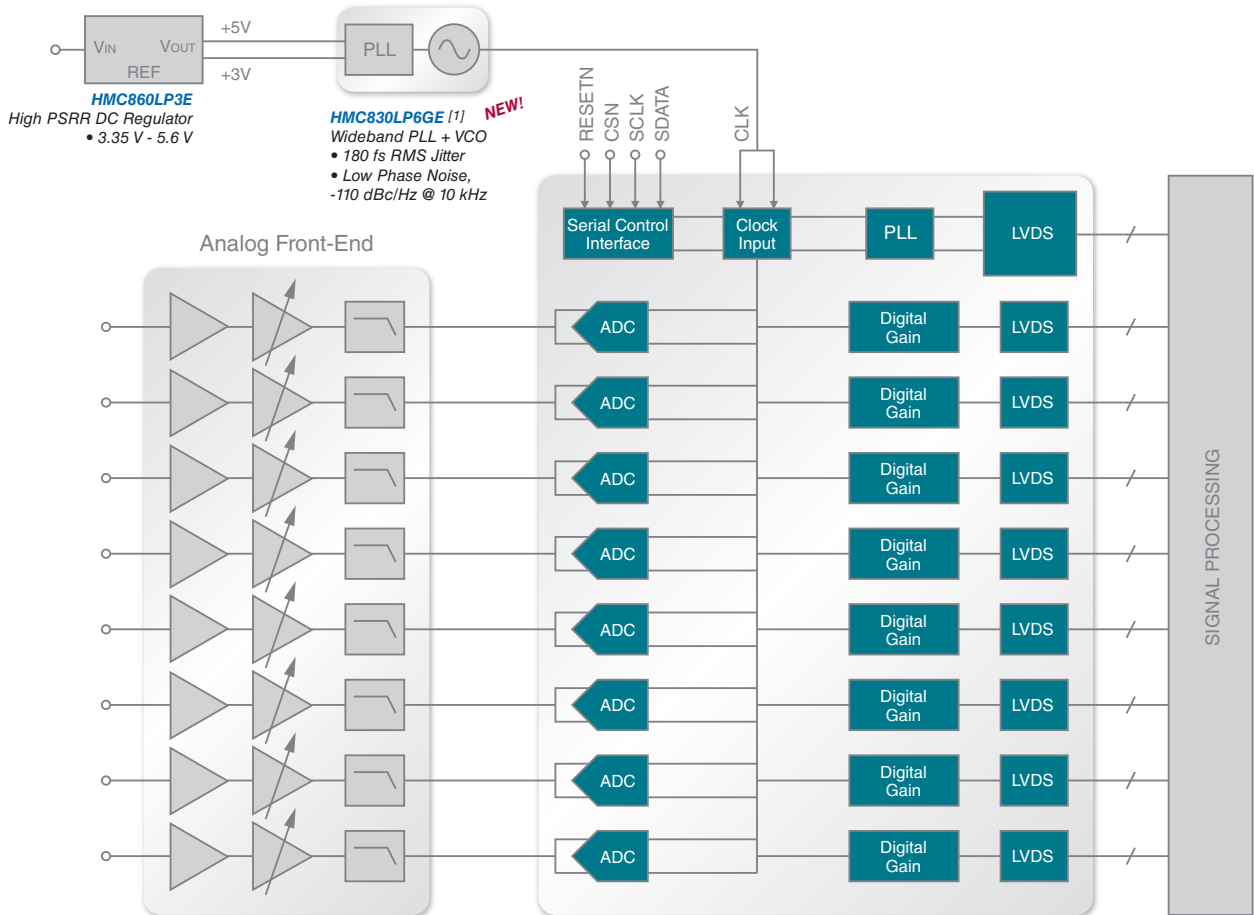

Part Number	Function / Mode	Resolution (bits)	Sample Rate	# of Channels	Power Dissipation [2][3]	SNR (dBFS)	SFDR (dBc)
HMCAD1102	Octal Channel	13 / 12	80 MSPS	8	59 mW / Channel	70.1	77
HMCAD1101	Octal Channel	13 / 12	65 MSPS	8	51 mW / Channel	72.2	82
HMCAD1100	Octal Channel	13 / 12	50 MSPS	8	41 mW / Channel	72.2	82

[2] Supply Voltage (Vdd): +1.8 Vdc Analog Supply (AVdd) and +1.8 Vdc Digital Supply (DVdd)
 [3] Output Supply Voltage (OVdd): +1.7 to +3.6 Vdc

[1] You may choose from a variety of HMC PLL+VCO combinations specific to your application

Hittite's Ultra High Speed GPS A/D Converters

In addition to the standard product, 3 to 1000 MSPS ADCs, Hittite offers ultra high bandwidth, non-interleaved flash and folding / interpolating-flash ADCs. These ADCs are capable of operating at sampling rates up to 26 GSPS and leverage Hittite's industry-leading track-and-hold design patents and advanced packaging capabilities. Operating over the full -55 °C to +85 °C temperature range, these ADCs are fully capable of supporting sub-sampling applications into Ku-band, and are ideal for wideband receiver systems and test instrumentation applications. Hittite can develop advanced flash and folding / interpolating-flash architecture ADCs to meet your custom specifications.

Atmospheric LIDAR Featuring the HMC5448 8-Bit, 5 GSPS A/D Converter

ULTRA HIGH SPEED A/D CONVERTERS

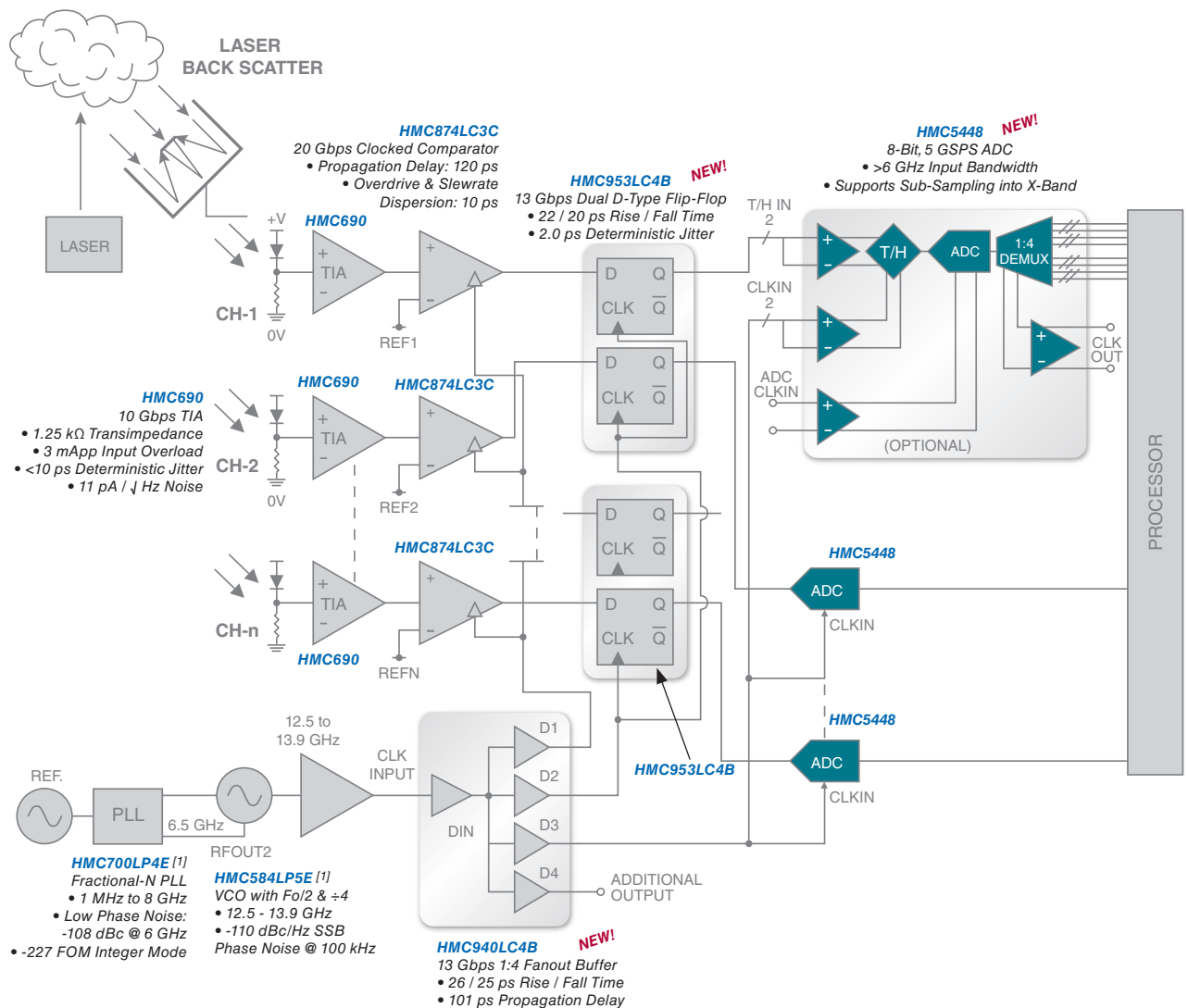

Please Contact: adc@hittite.com for Information on the HMC5448 Ultra High Speed ADC

[1] You may choose from a variety of HMC PLL+VCO combinations specific to your application

Radio Astronomy Featuring The HMC5831 3-Bit, 26 GSPS A/D Converter

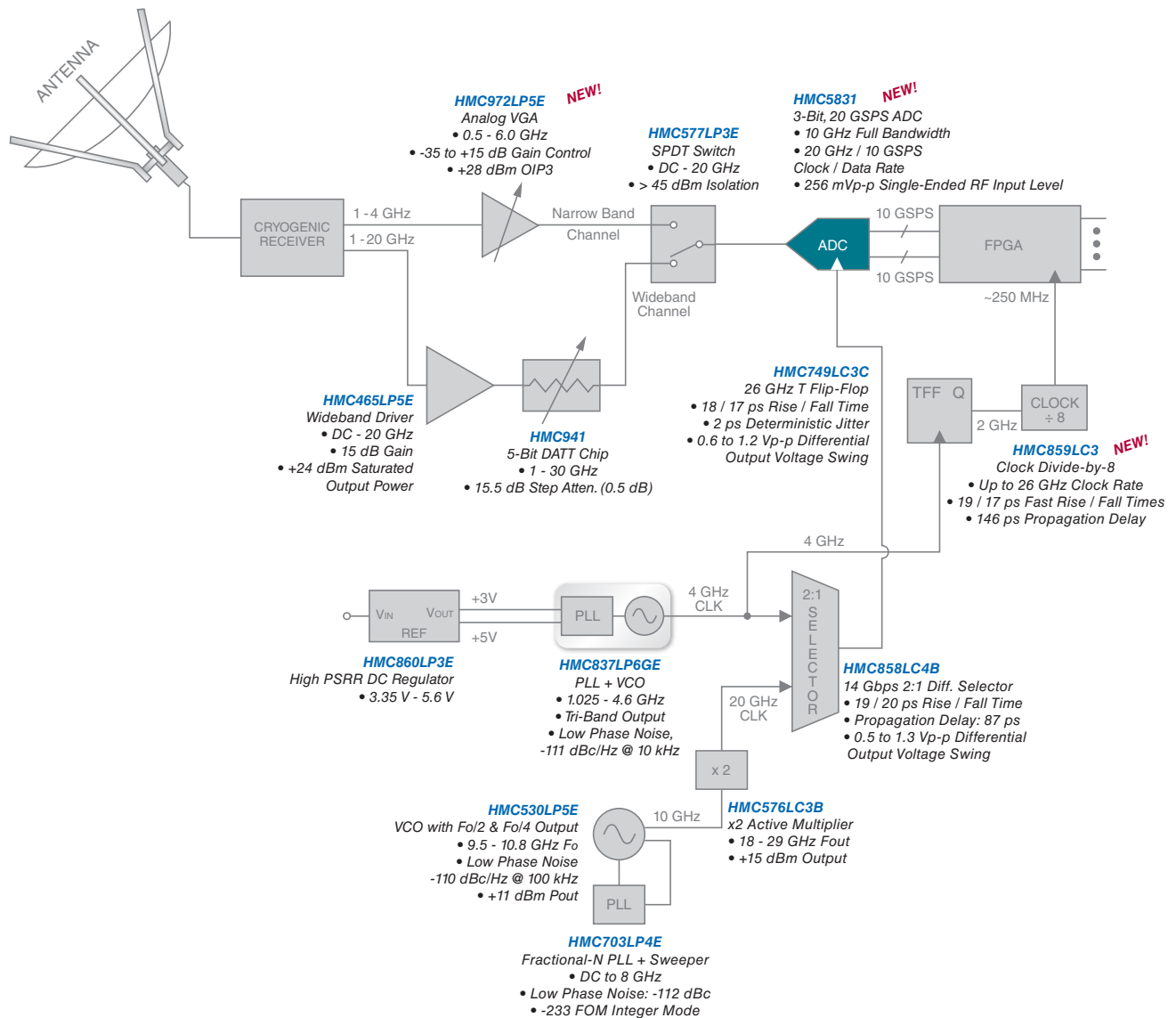

ULTRA HIGH SPEED A/D CONVERTERS

Please Contact: adc@hittite.com for Information on the HMC5831 Ultra High Speed ADC

CONNECTING OUR WORLD THROUGH INTEGRATED SOLUTIONS

SALES CONTACT INFORMATION:

Hittite Microwave Worldwide Sales Offices

Americas

**Hittite Microwave Corporation
USA Corporate Headquarters**
Phone: 978-250-3343
Fax: 978-250-3373
sales@hittite.com

Eastern (North) - North America

Boston, MA
Phone: 978-270-3167
usa-east-north@hittite.com

Eastern (South) - North America

Philadelphia, PA
Phone: 978-337-1226
usa-east-south@hittite.com

Central (North) - North America

Chicago, IL
Phone: 312-485-8730
usa-north@hittite.com

Central (South) - North America

Dallas, TX
Phone: 817-727-7146
usa-south@hittite.com

Western - North America

San Diego, CA
Phone: 978-250-3343
usa-west@hittite.com

Mexico, Central & South America

Dallas, TX
Phone: 978-250-3343 x1250
southamerica@hittite.com

Europe, Middle East & Africa

**United Kingdom, Ireland, Spain,
Portugal, Greece & Turkey**
Hittite Microwave Europe Limited
Phone: +44-7811-267418
Fax: +978-250-3373
europe@hittite.com

France, Italy & Benelux

Hittite Microwave Europe Limited
Phone: +44-7811-267418
Fax: +978-250-3373
europe@hittite.com

Northern Europe

Hittite Microwave Nordic AB
Phone: +46-761-763969
Fax: +978-250-3373
nordic@hittite.com

Finland Office

Phone: +46-761-763969
Fax: +46-8-752-9900
finland@hittite.com

Central & Eastern Europe

Hittite Microwave Deutschland GmbH
Phone: +49-8031-97654
Fax: +49-8031-98883
germany@hittite.com

Middle East & Africa

Hittite Microwave Europe Limited
Phone: +44-7811-267418
Fax: +978-250-3373
mea@hittite.com

Russia & Ukraine

Hittite Microwave Europe Limited
Phone: +44-7811-267418
Fax: +978-250-3373
russia@hittite.com
ukraine@hittite.com

Asia & Pacific

Australia & New Zealand

Hittite Microwave Corporation
Phone: 978-250-3343
Fax: 978-250-3373
ausnz@hittite.com

India

Hittite Microwave India
Phone: +91-9849134642
Fax: +978-250-3373
india@hittite.com

Republic of Korea

Hittite Microwave Asia Co., Limited
Phone: +82-2559-0638
Fax: +82-2559-0639
korea@hittite.com

Peoples Republic of China

Hittite Microwave Co., Limited
Shanghai Office
Phone: +86-21-6209-8809
Fax: +86-21-6209-6730
china@hittite.com

Shenzhen Office

Phone: +86-755-3322-2116
Fax: +86-755-3322-2117
shenzhen@hittite.com

Beijing Office

Phone: +86-10-6485 9219
Fax: +86-10-6485 0377
beijing@hittite.com

Xi'an Office

xi'an@hittite.com

Japan

Hittite KK
Phone: +81-3-5652-5772
Fax: +81-3-5652-6694
japan@hittite.com

Please Contact adc@hittite.com For All Standard & Custom ADC Product Solutions!

Order On-line at: www.hittite.com

© 2011, Hittite Microwave Corporation, All Rights Reserved.
2 Elizabeth Drive • Chelmsford, MA 01824 • 978-250-3343 tel • 978-250-3373 fax
Boston • Hyderabad • London • Munich • Seoul • Shanghai • Stockholm • Tokyo